



# BU01 Specification

Version V1.0

Copyright ©2019

## Disclaimer and copyright notice

The information in this article, including the URL address for reference, is subject to change without prior notice. The Documentation is provided "as is" without any warranty, including any warranties of merchantability, fitness for a particular purpose, or non-infringement, and any warranties mentioned in the proposal, specification or sample. This document is not responsible for any infringement of any patent rights arising out of the use of the information in this document. No license, express or implied, by estoppel or otherwise, is hereby granted.

The test data obtained in this paper are all obtained by Ai-Thinker laboratory, and the actual results may be slightly different. The Wi-Fi alliance membership mark is owned by the Wi-Fi alliance.

All trade mark names, trademarks and registered trademarks mentioned herein are the property of their respective owners and are hereby declared.

The final interpretation right is owned by Shenzhen Ai-Thinker Technology Co., Ltd.

### Note

The contents of this manual may be changed due to the version upgrade of the product or other reasons. Shenzhen Ai-Thinker Technology Co., Ltd. reserves the right to modify the contents of this manual without any notice. This manual is only used as a guide, and Shenzhen Ai-Thinker Technology Co., Ltd. makes every effort to provide accurate information in this manual, but Shenzhen Ai-Thinker Technology Co., Ltd. does not ensure that the contents of the manual are completely true, All statements and information in this manual, and the recommendations do not constitute for any warranty, express or implied.



## Contents

一、 Product Overview.....	5
二、 Electrical parameters.....	6
三、 Appearance size.....	7
四、 Pin definition.....	8
五、 Schematics.....	10
六、 Design Guidance.....	11
七、 Reflow Welding Curve.....	13
八、 Package Information.....	14
九、 Contacts.....	14

## 一、 Product Overview

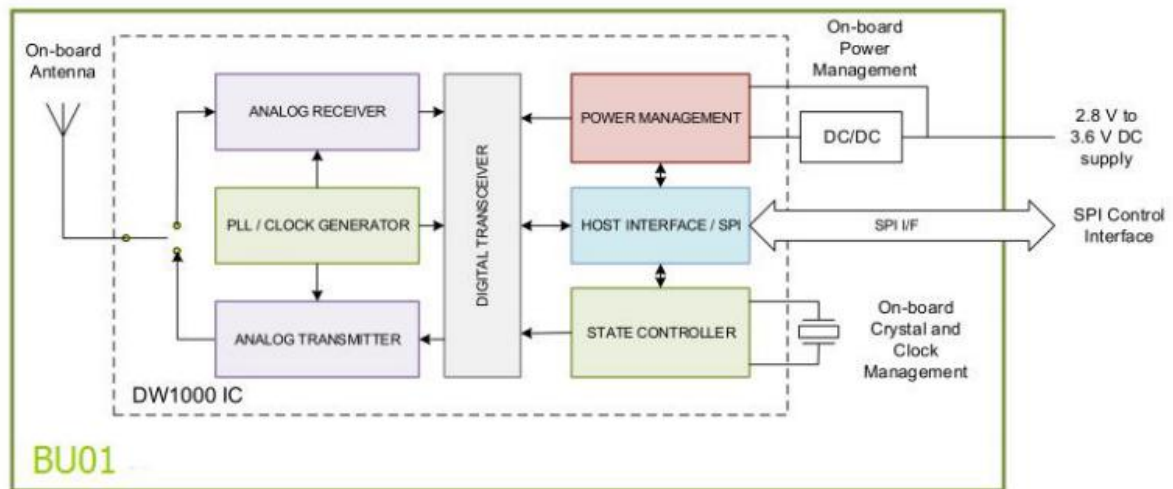

BU01 is an ultra wideband (UWB) transceiver module based on Decawave's DW1000 design. BU01 integrates antenna, RF circuit, power management and clock circuit. BU01 can be used in two-way ranging or TDOA positioning system, positioning accuracy can reach 10 cm, and supports data rates up to 6.8 Mbps.

### Features

- Simple integration without RF design
- Using RTLS infrastructure to expand communication range
- Super multipath fading has strong anti-interference ability
- Support high label density
- Compliant with IEEE 802.15.4-2011 UWB standard
- Supports 3.5 GHz to 6.5 GHz operating frequency band
- Programmable transmit power
- Power 2.8 V to 3.6 V
- Power consumption <1mA in sleep mode
- Support two-way ranging and TDOA
- Support SPI interface
- Data rate: 110 kbps, 850 kbps, 6.8 Mbps

## Main parameters

### List 1 specification

<b>Model name</b>	BU01
<b>Size</b>	23*13*2.9(±0.2)MM
<b>Antenna</b>	PCB antenna
<b>Frequency range</b>	3.5 GHz to 6.5 GHz
<b>Working temperature</b>	-20 °C ~ 85 °C
<b>Storage temperature</b>	-40 °C ~ 125 °C , < 90%RH
<b>Power</b>	2.8V ~ 3.6V, default 3.3V, current >200mA
<b>Interface</b>	SPI

## 二、 Electrical parameters

### Electrical character

Parameter		Condition	Min	Typical	Max	Unit
Voltage		VDD	2.8	3.3	3.6	V
I/O	$V_{IL}/V_{IH}$	-	-0.3/0.75V <sub>I/O</sub>	-	0.25V <sub>I/O</sub> /3.6	V
	$V_{OL}/V_{OH}$	-	N/0.8V <sub>I/O</sub>	-	0.1V <sub>I/O</sub> /N	V
	$I_{MAX}$	-	-	-	12	V

### RF performance

Description	Typical	Unit
Working frequency	3.5 GHz to 6.5	GHz

### 三、 Appearance size

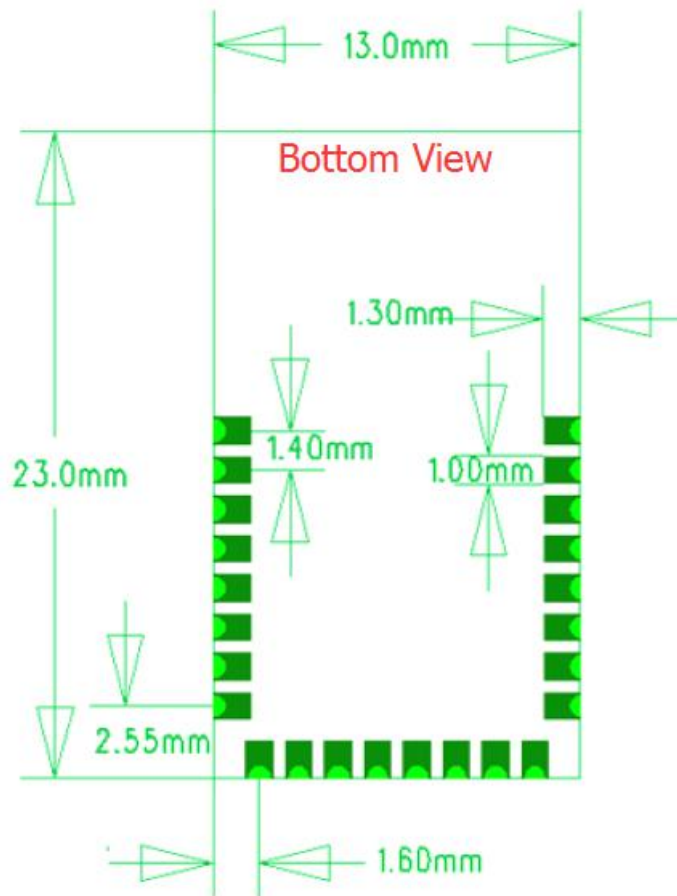
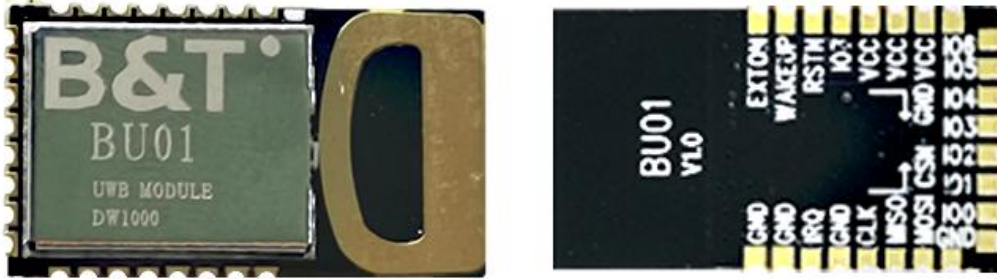

#### 四、 Pin definition

The BU01 module has a total of 24 interfaces. For example, the pin diagram, the pin function definition table is the interface definition.

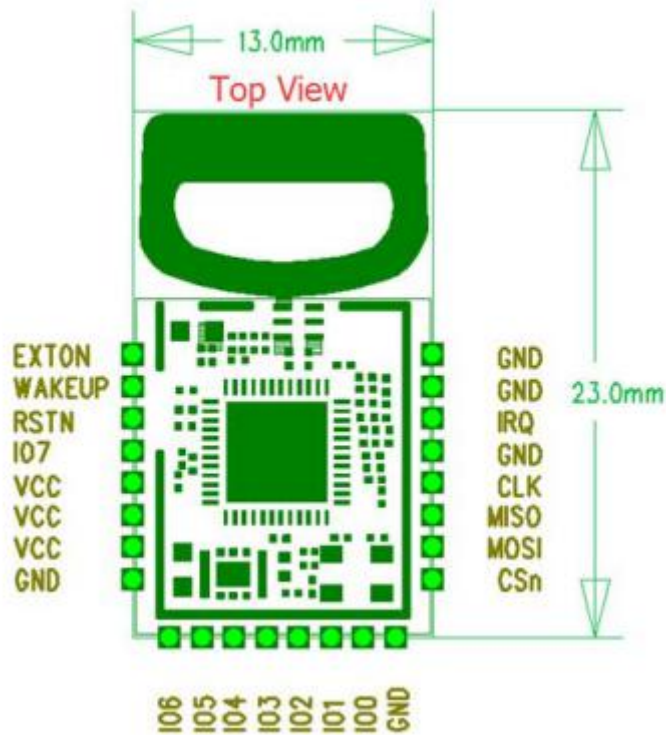

BU01 Pin diagram

List PIN function definition

PIN No.	Name	Function description
1	EXTON	The external device is enabled. Asserted and remains active during wake-up until the device enters sleep mode. Can be used to control external DC-DC converters or other circuits that are not needed when the device is in sleep mode to minimize power consumption. For more details, please refer to the DW1000 data sheet
2	WAKEUP	When set to the active high state, the WAKEUP pin brings the DW1000 from sleep or DEEPSLEEP state into working mode. If not used, this pin can be grounded.
3	RSTn	Reset pin. Active low output. Can be pulled low by an external open-drain driver to reset
4	I07	The default value is used as the SYNC input. This pin can be reconfigured as a general purpose I / O pin GPIO7 under



		software control.
5	VCC	3.3 V power
6	VCC	3.3 V power
7	VCC	3.3 V power
8	GND	Ground
9	I06	General purpose I / O pin. At power-up, it is used as the SPIPHA (SPI Phase Select) pin to configure the SPI operating mode. After power-up, this pin will default to a general-purpose I / O pin.
10	I05	General purpose I / O pin. At power-up, it is used as an SPIPOL (SPI Polarity Select) pin to configure the SPI operating mode. After power-up, this pin will default to a general-purpose I / O pin.
11	I04	Universal I / O PIN.
12	I03	General purpose I / O pin. It can be configured to be used as a TXLED drive pin, which can be used to light the LED after transmission.
13	I02	General purpose I / O pin. It can be configured as a RXLED drive pin, which can be used to light the LED in receive mode.
14	I01	General purpose I / O pin. It can be configured to be used as an SFDLED drive pin, which can be used to light the LED when the receiver finds an SFD (Start Frame Delimiter).
15	I00	General purpose I / O pin. It can be configured as a RXOKLED drive pin, which can be used to light the LED after receiving a good frame.
16	GND	Ground
17	CSn	SPI chip selection. This is an active-low enable input. A high-to-low transition on SPICSn indicates the start of a new SPI transaction. SPICSn can also be used as a wake-up signal to bring the DW1000 out of sleep or sleep.
18	MOSI	SPI data input
19	MISO	SPI data output
20	CLK	SPI clock
21	GND	Ground
22	IRQ	Interrupt request output from DWM1000 to the host processor.

		By default, IRQ is an active-high output, but it can be configured to be active-low if required. For proper operation in SLEEP and DEEPSLEEP modes, they should be configured for active-high operation. This pin will float in Sleep and DEEPSLEEP states, and unless pulled low, it may cause spurious interrupts. When the IRQ function is not used, this pin can be reconfigured as a general purpose I / O line, GPIO8.
23	GND	Ground
24	GND	Ground

## 五、 Schematics

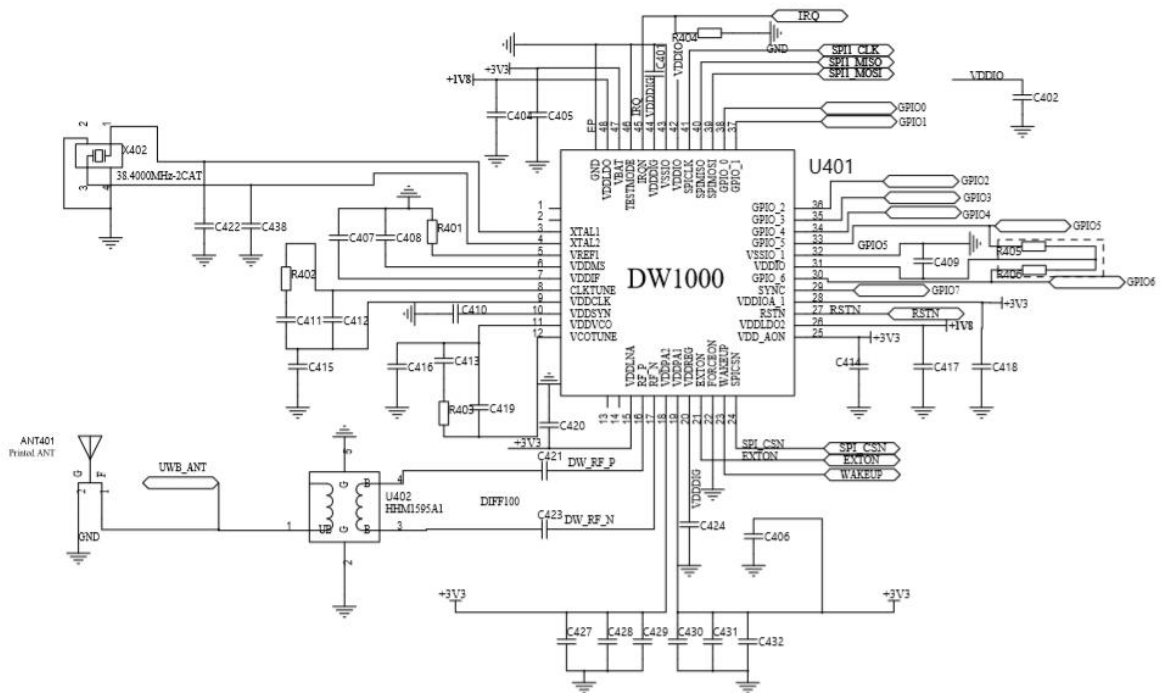

## 六、 Design Guidance

### 1、 Application circuit

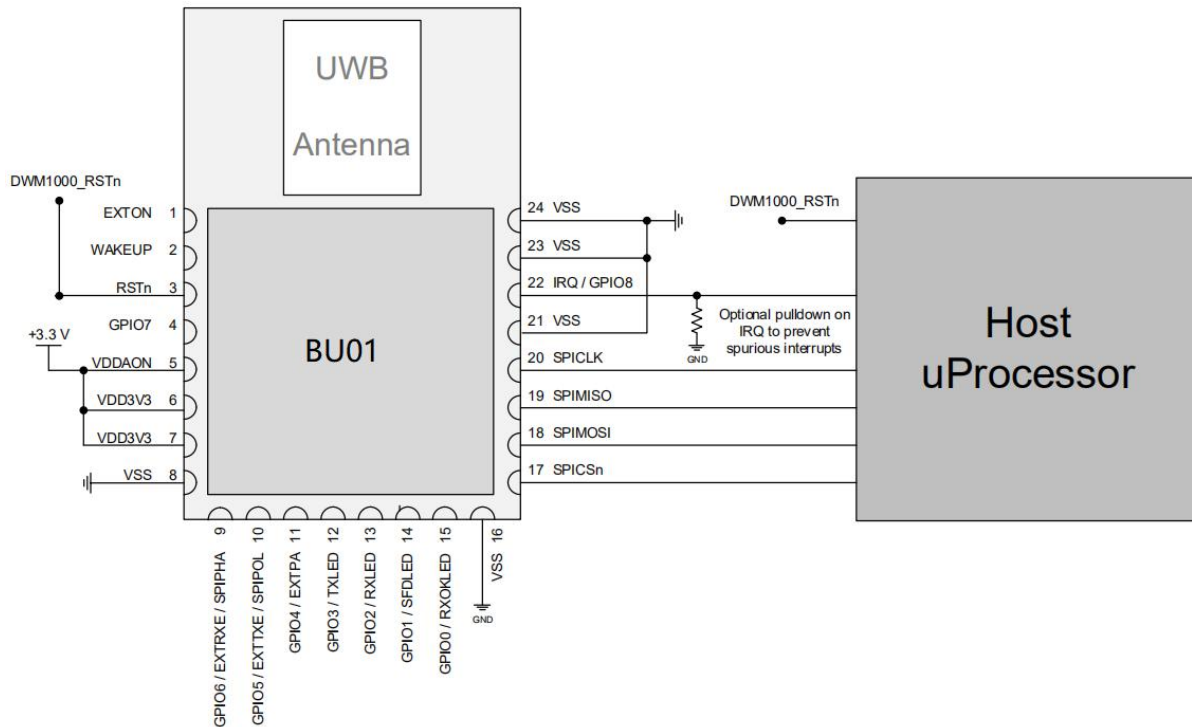

### 2、 Antenna layout requirements

(1) For the installation position on the motherboard, the following two methods are recommended:

Solution 1: Place the module on the edge of the motherboard, and the antenna area extends beyond the edge of the motherboard.

Solution 2: Place the module on the edge of the motherboard, and the edge of the motherboard hollows out an area at the antenna position.

(2) In order to meet the performance of the on-board antenna, it is forbidden to place metal parts around the antenna and keep it away from high-frequency devices.

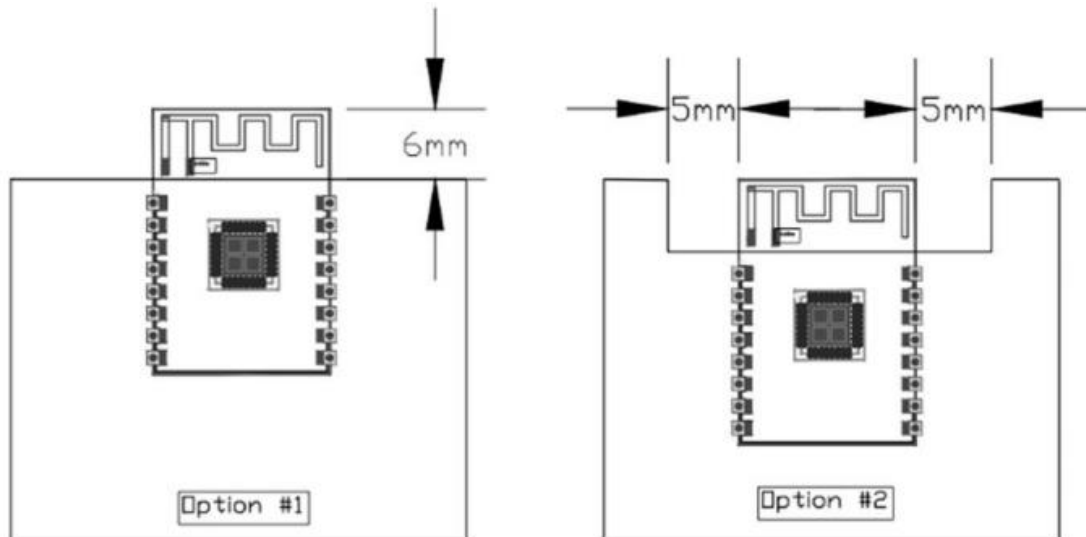

### 3、Power

- (1) Recommended 3.3V voltage, peak current above 200mA
- (2) It is recommended to use LDO power supply; if using DC-DC, it is recommended to control the ripple within 30mV.
- (3) The DC-DC power supply circuit is recommended to reserve the position of the dynamic response capacitor, which can optimize the output ripple when the load changes greatly.
- (4) 3.3V power interface is recommended to add ESD devices.

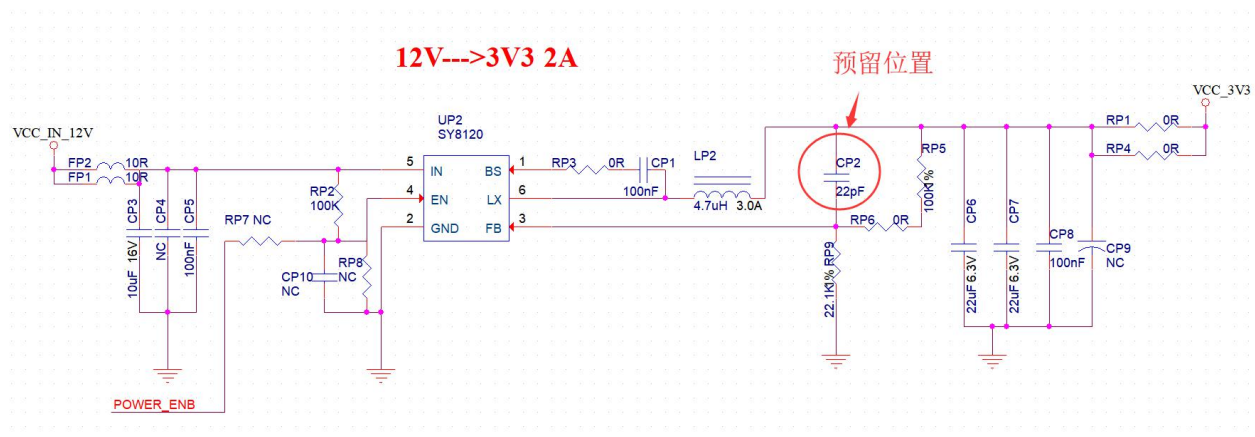

### 4、USE of GPIO port

- (1) There are some GPIO ports on the periphery of the module. If you need to use a 10-100 ohm resistor in series with the IO port, it is recommended. This can suppress overshoot, and the levels on both sides are more stable. Used for both EMI and ESD.
- (2) The special IO port is pulled up and down, please refer to the instruction manual of the specification, this will affect the startup configuration of the module.
- (3) The IO port of the module is 3.3V. If the IO level of the main control and the module does not match, a level conversion circuit needs to be added.
- (4) If the IO port is directly connected to a peripheral interface, or a pin or other terminal, it is

recommended to reserve an ESD device near the terminal of the IO trace.

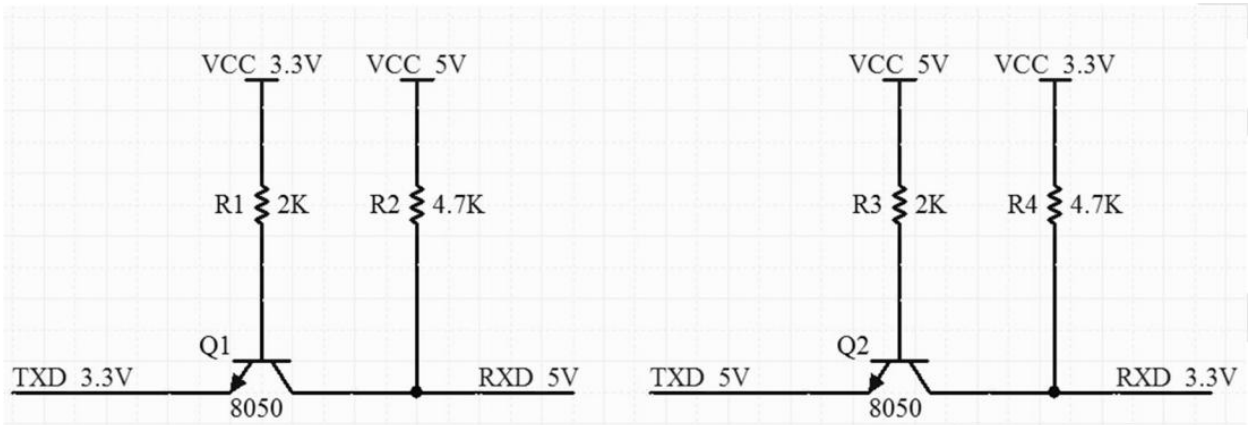

List Level-shifting circuit

## 七、 Reflow Welding Curve

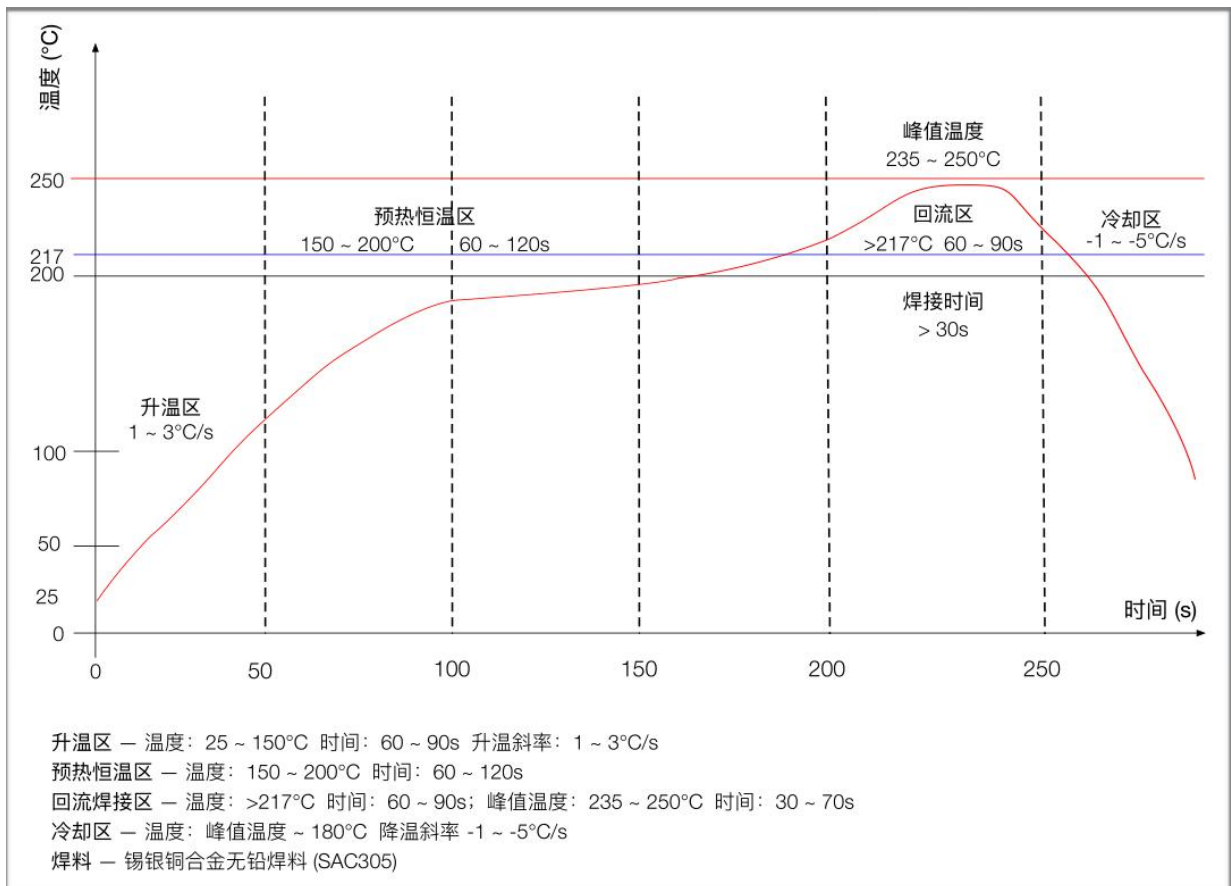

## 八、 Package Information

As shown below, the packing of BU01 is taping.



## 九、 Contacts

Company website: <https://www.ai-thinker.com>

Developer DOCS: <https://docs.ai-thinker.com>

Company forum: <http://bbs.ai-thinker.com>

Sample purchase: <https://anxinke.taobao.com>

Business cooperation: [sales@aithinker.com](mailto:sales@aithinker.com)

Technology support: [support@aithinker.com](mailto:support@aithinker.com)

Company address : 410, Building C, Gufeng Huafeng Smart Innovation Port, Xixiang, Baoan District, Shenzhen

Contacts: 0755-29162996

